

## ACO PowerVAC

# Vacuum Generation

The ACO PowerVAC vacuum pumping unit forms the centrepiece of the centralised vacuum toilet collection and transfer system. The ACO PowerVAC unit is designed to create a powerful vacuum within the vacuum line network to ensure an efficient and reliable sewage collection and transfer direct to a wastewater treatment plant, holding tank or to shore discharge.

The ACO PowerVAC improved design consists of one or more pumps connected directly to a wastewater treatment plant or holding tank without the need for a temporary collection reservoir.

The compact, close-coupled pump design provides a small footprint, which makes the unit ideal where space is limited.

The ACO PowerVAC unit is simple to install and service thanks to its compact and well thought-out Easy-to-Maintain design.



## ACO PowerVAC Efficient & flexible vacuum generation units for marine applications

- Designed for vacuum toilet, black water collection systems & wastewater transfer
- Optimized design of backflow flap minimizes a risk of squeezed solid parts in the backflow flap and consequently a leakage of the vacuum system.
- Powerful macerator significantly minimizes a risk of blockage of the pump
- Five connection points for emptying or additional sensors.
- Special housing of mechanical seal to avoid dirt in the gasket.
- High quality pump materials and mechanical seal system.
- Pumps are designed according to the easy-to-maintain principle. Easy access to the pumping elements, wear parts and sealing system by simply removing the 'wet end' pump cover
- Bespoke specifications are available on request to match on-board requirements.

### Process description

The ACO PowerVAC Vacuum Pump is a simple and efficient vacuum pump with an integrated macerator on the same shaft. The eccentrically positioned screw shaped impeller spins pumping water around the perimeter of the pump housing and that way it creates vacuum on the suction side and simultaneously pumps waste water from the vacuum sewage system.

The backflow flap on the suction side seals the vacuum sewage system within the time when the pump does not run.

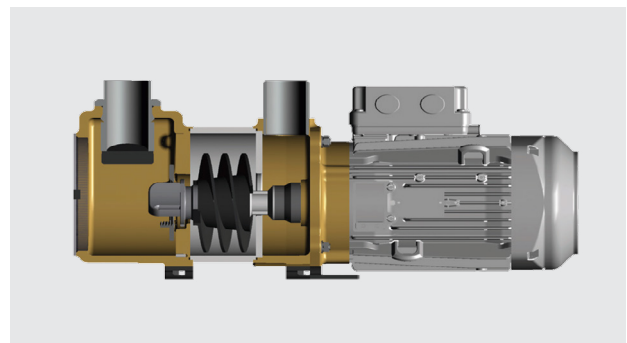

## ACO PowerVAC Vacuum Pumps

Type	Operating Data						Dimensions						
	Air capacity up to		Flushing capacity up to		Nominal Power		Voltage *	L	W	H	Inlet	Outlet	Weight
	m <sup>3</sup> /h		flushes/h		kW								
50 Hz	60 Hz	50 Hz	60 Hz	50 Hz	60 Hz	Volts	mm	mm	mm	mm	mm	kg	
<b>15</b>	13.7	15.0	120	150	2.2	2.6	380 ~ 440	572	212	326	Hose Ø48,3	Hose Ø48,3	35
<b>25</b>	22.0	25.0	190	240	3.0	3.6	380 ~ 440	704	195	381	Hose Ø60,3	Hose Ø60,3	65
<b>25-F</b>	22.0	25.0	190	240	3.0	3.6	380 ~ 440	704	195	275	Flange DN50, PN10	Flange DN32, PN10	65
<b>70-F</b>	70.0	85.0	730	800	5.5	6.4	380 ~ 440	838	252	448	Flange DN65, PN10	Flange DN50, PN10	100

NOTE: \* Other voltages are available on request

## ACO PowerVAC Vacuum Stations

Type	Operating Data						Dimensions							
	Air capacity up to		Flushing capacity up to		Nominal Power		Voltage *	L	W	H	Inlet Flange	Outlet Flange	Weight	Article
	m <sup>3</sup> /h		flushes/h		kW									
50 Hz	60 Hz	50 Hz	60 Hz	50 Hz	60 Hz	Volts	mm	mm	mm	mm	mm	kg		
<b>Dual pump station</b>														
<b>2x15</b>	2x13.7	2x15.0	2x120	2x150	2x2.2	2x2.6	380 ~ 440	590	700	1165	DN50, PN10	DN50, PN10	140	447809
<b>2x25</b>	2x22.0	2x25.0	2x190	2x240	2x3.0	2x3.6	380 ~ 440	790	700	1405	DN65, PN10	DN65, PN10	215	447810
<b>2x70-F</b>	2x70.0	2x85.0	2x730	2x800	2x5.5	2x6.4	380 ~ 440	840	795	1705	DN80, PN10	DN80, PN10	340	447811
<b>Single pump station</b>														
<b>1x15</b>	13.7	15.0	120	150	2.2	2.6	380 ~ 440	585	475	1165	DN50, PN10	DN50, PN10	88	449740
<b>1x25</b>	22.0	25.0	190	240	3.0	3.6	380 ~ 440	777	475	1405	DN50, PN10	DN50, PN10	125	449741

NOTE: \* Other voltages are available on request

